

**Design Number BS/SFWT 60-08
 OPEN JOIST 2000® JOIST SERIES**

By Barrette Structural Inc.
 ASTM E119 and CAN/ULC S101
 Load Bearing Fire Resistance Rated Roof/Ceiling, Floor/Ceiling Assembly
 1-Hour Fire Rating

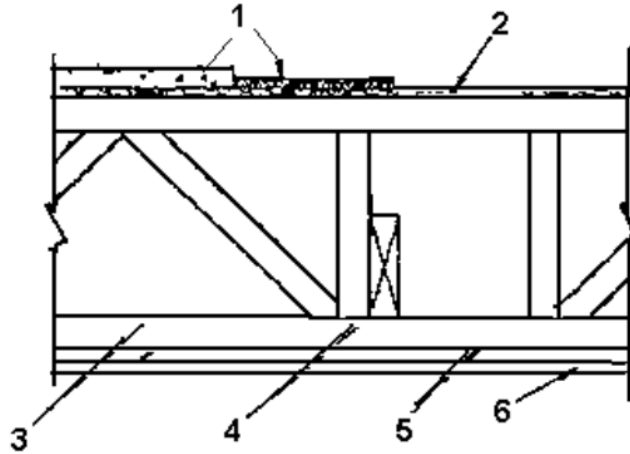

Acoustic Performance for 11-7/8 in. Depth Joist

Required Components	STC	IIC
With carpet, pad and insulation	53	72
With carpet, pad without insulation	52	67
With vinyl flooring and insulation	53	50
With vinyl flooring without insulation	52	---
Bare Gypcrete and insulation	53	---
Bare Gypcrete without insulation	52	---

Note:

- Carpet and pad are 37 oz., 7/8 in. carpet with woven polypropylene backing and 40 oz. felt pad
- Vinyl flooring: Armstrong Starstep
- 3/4 in. Gypcrete 2000

1. **FLOOR TOPPING (Optional):** Gypsum concrete, lightweight or normal concrete topping.
2. **SUB-FLOORING:** Min. 5/8 in. thick plywood or OSB or equivalent.
3. **CERTIFIED MANUFACTURER:** Barrette Structural Inc.

CERTIFIED PRODUCT: Open Joist Series

CERTIFIED MODEL: Open Joist 2000®

 Open Joist 2000®, 9-1/4 in. min. depth, installed up to 24 in. oc, with structural graded nominal 2 x 3 or 2 x 4 chords per

NLGA grading rules. Structural member should bear the Intertek certification mark.

4. **BRIDGING:** Continuous 2 x 4 lumber nailed to the bottom chord and the sides of the diagonals with 2 in. long nails at 7 ft. oc.
5. **RESILIENT CHANNEL:** Min. 0.019 in. thick galvanized steel resilient channels, attached perpendicular to joists using 1-5/8 in. long drywall screws. Resilient channels spaced 16 in. oc. Additional channels are required at gypsum board end joints so that each board is attached to a separate channel. These additional channels shall extend to the next joist on each side of the board end joint.

6. **GYPSUM BOARD:** Min. 5/8 in. thick Type C gypsum wallboard installed with long dimension perpendicular to resilient channels and fastened to each channel with min. 1-1/8 in. long Type S drywall screws. Fasteners spaced 7 in. oc and 1-1/2 in. from panel edges and ends. Edge joints shall be centered between joists. End joints shall be staggered one channel spacing.
7. **INSULATION (Not Shown):** Min. 2 in. thick mineral wool insulation batts – 3.5 pcf (min.), friction fitted between the bottom flanges of the joists and supported by setting strip edges. Ends of batts shall be centered over resilient channels and tightly butted.
8. **FINISH SYSTEM (Not Shown):** Face layer joints covered with tape and coated with joint compound. Screw heads covered with joint compound.
9. **SETTING STRIPS (Not Shown):** Min. 1x4 (nominal) wood setting strips attached with 1-1/2 in. long drywall screws at 24 in. oc along the bottom flange of joist creating a ledge to support insulation.